

1 1/2" & 2" PISTON HEAD PARTS



PROMAG ENVIRO

Leader in Water & Waste Water Treatment Supply

CALL US TOLL FREE 1.866.449.2781

www.promagenviro.com info@promagenviro.com

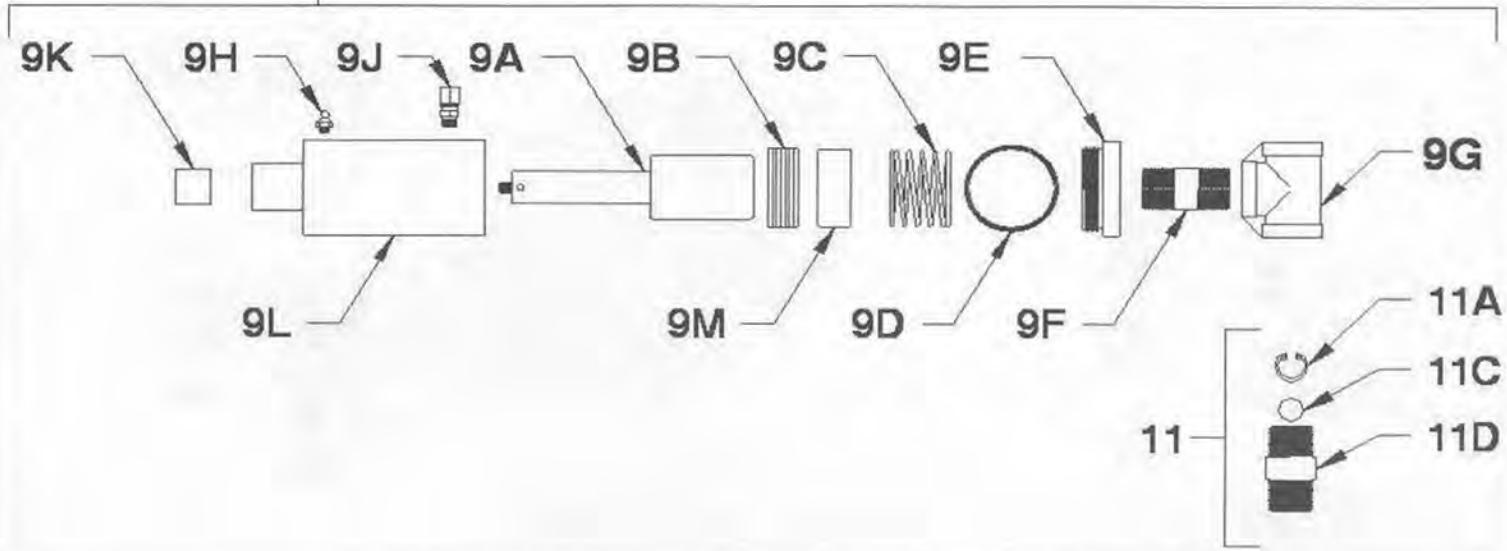
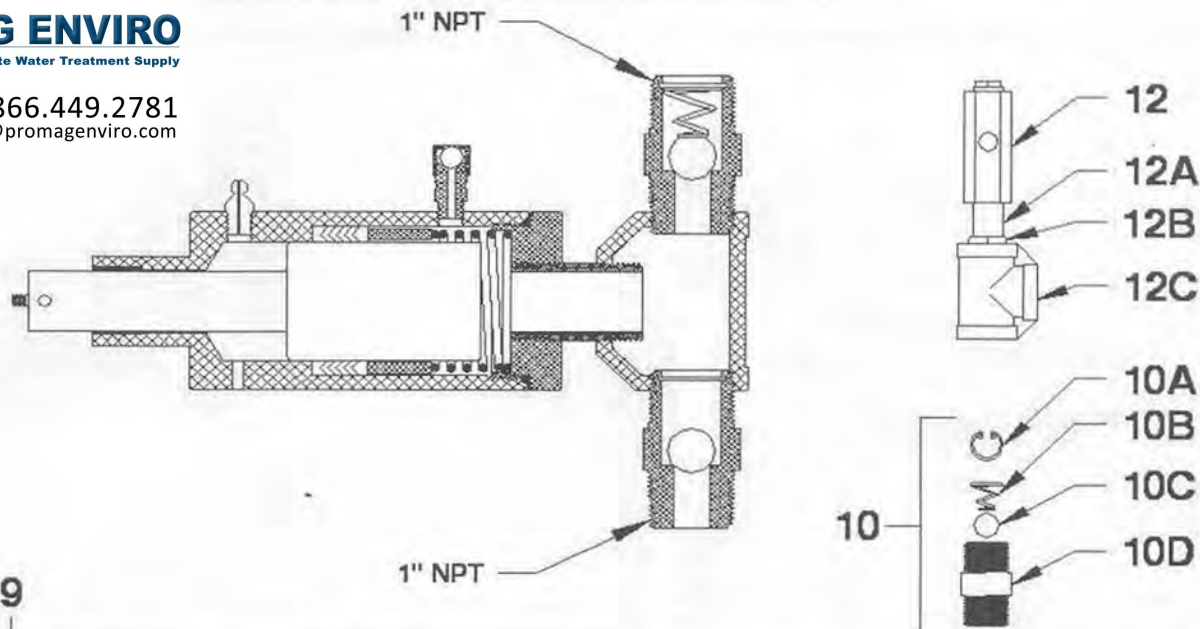

ITEM	PART #	DESCRIPTION
9	1000-7	1 1/2" CS PISTON HEAD ASSEMBLY** W/CKS
	1000-8	2" CS PISTON HEAD ASSEMBLY** W/CKS
9A*	007-8	1 1/2" DIAMETER 303SS PISTON***
	007-9	2" DIAMETER 303SS PISTON***
9B*	012-8	1 1/2" PACKING SET (BUNA N)*****
	012-9	2" PACKING SET (BUNA N)*****
9C	017-20	1 1/2" & 2" PACKING SPRING
9D*	017-21	2 1/2" ID X 1/8" CROSS SECTION "O" RING SEAL
9E	003-20	1 1/2" & 2" CS END CAP****
9F	002-13	1" NPT X CLOSE BLACK NIPPLE
	002-13-S	1" NPT X CLOSE 316SS NIPPLE
9G	002-12	1" NPT BLACK TEE
	002-12-S	1" NPT 316SS TEE
9H	006-1	GREASE FITTING
9J	017-17-S	316SS VENT CHECK
9K	008-20	1 1/8" X 1" X 1" OILITE BUSHING
9L	001-20	1 1/2" & 2" CS PUMP HEAD SHELL****
9M	018-1	1 1/2" PACKING SPACER
	018-2	2" PACKING SPACER

*** RECOMMENDED SPARE PARTS**

CS-CARBON STEEL
C20-ALLOY 20

ITEM	PART #	DESCRIPTION
10*	002-19-D	303SS DISCHARGE CHECK VALVE ASSEMBLY***
10A	16-SS	SS SNAP RING BALL RETAINER
10B	002-27	ANTI-SIPHON CONE SPRING
10C	002-17	3/4" DIAMETER 316SS BALL CHECK
10D	002-18	303SS CHECK VALVE BODY***
11*	002-19-S	303SS SUCTION CHECK VALVE ASSEMBLY***
11A	16-SS	SS SNAP RING BALL RETAINER
11C	002-17	3/4" DIAMETER 316SS BALL CHECK
11D	002-18	303SS CHECK VALVE BODY***
12	36	1/2" NPT 303SS PRESSURE RELIEF VALVE
12A		1/2" NPT X 1 1/2" BLACK NIPPLE
12B		1" NPT X 1/2" NPT BLACK BUSHING
12C	002-12	1" NPT BLACK TEE

OPTIONAL MATERIALS

**	303SS	ADD \$430 LIST
	316SS	ADD \$600 LIST
	C20	ADD \$1550 LIST

***	316SS	ADD \$60 LIST
	C20	ADD \$140 LIST

****	303SS	ADD \$215 LIST
	316SS	ADD \$320 LIST
	C20	ADD \$780 LIST

*****	TEFLON	ADD \$40 LIST
	VITON	ADD \$40 LIST