

# ORIGINAL MUNI-BALL® PLUGS

The Muni-Ball® Plug was introduced over 50 years ago and the Cherne brand continues to be the most trusted name in pneumatic plugs today. Muni-Ball® Plugs offer a full bypass allowing both testing and monitoring of piping systems. Muni-Balls® are ideal for installation and repair of residential or commercial piping systems. Cherne Muni-Ball® products can also be used for maintenance of municipal infrastructure, including sanitary and storm sewer pipe systems. Muni-Ball® plugs are durable, rugged and are effective on almost any type of pipe.

## Features:

- Muni-Ball® Plugs are supplied with Schrader tire inflation valves
- Larger diameter Muni-Ball® Plugs include a removable threaded valve, allowing the user to replace with quick disconnect fittings
- Multi-Size® Muni-Ball® Plugs allow more options and less inventory
- 8", 10", 12" and 15" Sizes now include modified plug (078751) for sewer air tests

## Bypass Pumping

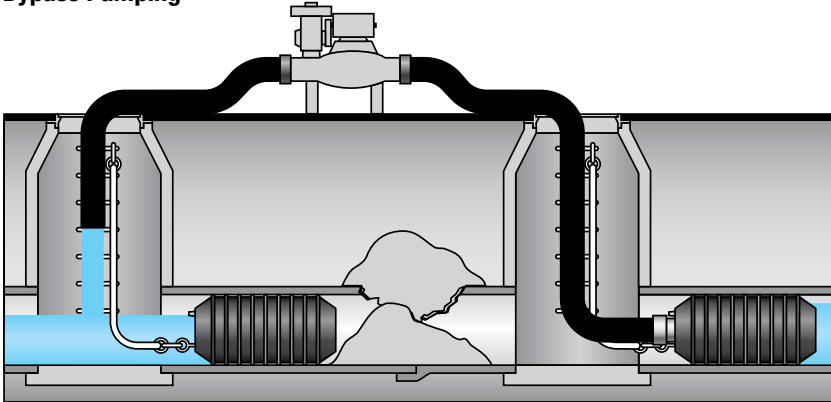

## Sewer Air Test

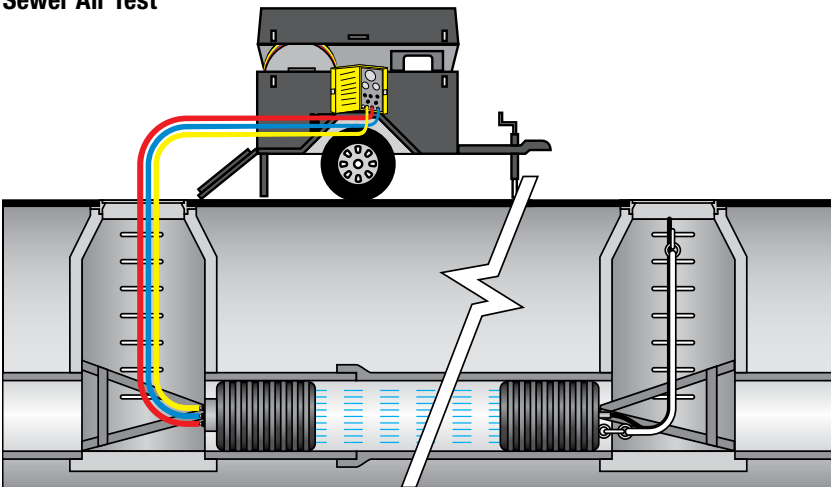



## SINGLE SIZE



PART NUMBER	NOM. SIZE	BYPASS DIAMETER (NPT)	USAGE RANGE	MAXIMUM BACK PRESSURE	INFLATION PRESSURE	PRODUCT WEIGHT	DEFLATED LENGTH	DEFLATED DIAMETER	INFLATION THREAD	CHAIN / EYE BOLTS
262008	1.5" (40 mm)	1/4" M	1.49"-1.88" (38-48 mm)	22 psi (1,5 bar)	50 ft (15 M)	40 psi (2,8 bar)	0.3 lbs (0.2 kg)	3.8" (97 mm)	1.4" (36 mm)	Molded in Valve Removable Chain
262010	2" (50 mm)	1/8" F	1.88"-2.25" (48-57 mm)	22 psi (1,5 bar)	50 ft (15 M)	40 psi (2,8 bar)	0.4 lbs (0.3 kg)	6" (152 mm)	1.75" (44 mm)	Molded in Valve Removable Chain
262038	2.5" (64 mm)	1/8" F	2.25"-2.75" (57-70 mm)	15 psi (1 bar)	35 ft (11 M)	40 psi (2,8 bar)	0.6 lbs (0.27 kg)	5.7" (145 mm)	2.07" (53 mm)	Molded in Valve Removable Chain
262258	3" (75 mm)	1/2" F	2.62"-3.25" (67-83 mm)	22 psi (1,5 bar)	50 ft (15 M)	40 psi (2,8 bar)	1.25 lbs (0.5 kg)	8" (203 mm)	2.5" (64 mm)	Molded in Valve Removable Chain
262048	4" (100 mm)	3/4" F	3.25"-4.25" (83-108 mm)	22 psi (1,5 bar)	50 ft (15 M)	40 psi (2,8 bar)	1.5 lbs (0.7 kg)	8" (203 mm)	3.13" (80 mm)	Molded in Valve 1/4" (1)
262064	6" (150 mm)	1 1/2" F	4.50"-6.25" (144-159 mm)	13 psi (0,9 bar)	30 ft. (9.1 M)	35 psi (2,4 bar)	2 lbs (1 kg)	7" (178 mm)	4.5" (112 mm)	1/8" 1/4" (1)
262080	8" (200 mm)	3" F	7.00"-8.25" (178-210 mm)	13 psi (0,9 bar)	30 ft. (9.1 M)	35 psi (2,4 bar)	5 lbs (2.3 kg)	10" (254 mm)	6.75" (170 mm)	1/4" 3/8" (1)
262110	10" (250 mm)	3" F	9.00"-10.25" (229-260 mm)	13 psi (0,9 bar)	30 ft. (9.1 M)	35 psi (2,4 bar)	9 lbs (4 kg)	11.75" (298 mm)	8.75" (222 mm)	1/4" 3/8" (1)
262129	12" (300 mm)	3" F	10.50"-12.25" (267-311 mm)	13 psi (0,9 bar)	30 ft. (9.1 M)	35 psi (2,4 bar)	13 lbs (6 kg)	13.75" (350 mm)	10.25" (260 mm)	1/4" 3/8" (1)
262137	15" - 16" (375-400 mm)	3" F	14.0"-16.0" (356-413 mm)	13 psi (0,9 bar)	30 ft. (9.1 M)	35 psi (2,4 bar)	33 lbs (15 kg)	19.75" (502 mm)	13.75" (346 mm)	1/4" 3/8" (1)
262188	18" (450 mm)	4" F	17.5"-19.5" (445-504 mm)	13 psi (0,9 bar)	30 ft. (9.1 M)	25 psi (1,7 bar)	79 lbs (36 kg)	24.75" (629 mm)	16.9" (429 mm)	1/4" 1/2" (2)
262218	21" (525 mm)	4" F	18.55"-21.38" (479-543 mm)	13 psi (0,9 bar)	30 ft. (9.1 M)	25 psi (1,7 bar)	87 lbs (39 kg)	26" (660 mm)	18.25" (462 mm)	1/4" 1/2" (2)
262242	24" (600 mm)	4" F	22.0"-25" (558-632 mm)	13 psi (0,9 bar)	30 ft. (9.1 M)	25 psi (1,7 bar)	124 lbs (56 kg)	28.75" (730 mm)	21.25" (538 mm)	1/4" 1/2" (2)

## MULTI-SIZE

PART NUMBER	NOMINAL SIZE	BYPASS DIAMETER (NPT)	USAGE RANGE	MAXIMUM BACK PRESSURE	INFLATION PRESSURE	PRODUCT WEIGHT	DEFLATED LENGTH	DEFLATED DIAMETER	INFLATION THREAD	CHAIN / EYE BOLTS
265048	4" - 6" (100-150 mm)	3/4" F	3.75"-6.25" (95-159 mm)	17 psi (1,2 bar)	40 ft (12 M)	35 psi (2,4 bar)	2.5 lbs (1.1 kg)	10.75" (273 mm)	3.46" (88 mm)	1/8" 1/4" (1)
265068	6" - 8" (150-200 mm)	1 1/2" F	5.50"-8.35" (133-212 mm)	17 psi (1,2 bar)	40 ft (12 M)	35 psi (2,4 bar)	6 lbs (2.7 kg)	13" (330 mm)	5" (125 mm)	1/4" 3/8" (1)
265078	8" - 10" (22-250 mm)	2" F	7.00"-10.25" (178-260 mm)	17 psi (1,2 bar)	40 ft (12 M)	30 psi (2,1 bar)	9 lbs (3 kg)	14.5" (368 mm)	6.75" (171 mm)	1/4" 3/8" (1)