

Overview

Walchem and Iwaki have created a unique partnership with over 100 years combined pump experience in an array of different markets. This talent has led to the design of the most innovative and comprehensive metering pump product line in the world, the E-Class Metering Pumps.

E-Class features four great series: EZ, EW, EK and EHE. The variety of pumps within the E-Class will fit any water treatment, wastewater, agriculture, water conditioning, car wash or other industrial feed application.



EW Series

E-Class Metering Pumps

Summary of Benefits

■ High Speed Performance

E-Class pumps operate at 360 strokes-per-minute. Most competitive products operate at 180 SPM or less resulting in slug feeding, accelerated diaphragm wear and poor feed control.

■ Dual Bearing Support

All E-Class pumps features dual bearing support. The armature and shaft are supported with a bearing on each end, which ensures proper axial movement, enabling the E-Class to operate at 360 SPM while extending the life of the diaphragm.

■ Superior Check Valve Performance

Dual Check Valve Assemblies, in both suction and discharge fittings, feature precision ball guides and tapered seats. Precise machining and molding of parts limit valve ball travel, ensuring that balls fully seat and seal with every stroke. This superior check valve design and performance guarantees fast priming.

■ High Compression Ratio

The compression ratio of a metering pump is important because it affects the pump's ability to prime and vent. The compression ratio is raised when you reduce the dead volume of the pump head during operation. All E-Class pumps feature a very high compression ratio that ensures proper feed, especially with off-gassing products (i.e.. Sodium Hypochlorite).



EW Series

The EW Series is the flagship of the E-Class with capacities up to 6.7 GPH (25.4 l/h) and a maximum pressure of 150 PSI (10 bar). Compact, powerful and packed with a variety of innovative design features, the EW can enhance any feed application. A variety of liquid end combinations are available to ensure a perfect match for your specific application.

IP65 Construction

The rugged Polyphenylene Oxide (PPO) enclosure is equipped with a durable clear cover to protect the membrane switches and stroke control of the pump, which are mounted opposite the liquid end. The display utilizes a high temperature LCD that provides extra protection from sunlight in outdoor applications.



PVC

GFRPP

PVDF

316SS

Control Features

All EW Series pumps come equipped with pulse and stop input/output control.

Feed Accuracy - Powered by the E-Class 360 Stroke-Per-Minute technology, the EW has an incredible adjustment range of 1800:1, ensuring precise feed control for any application.

Pulse Output - The EW pump is capable of sending a pulse out synchronous with pump operation.



Stop Input/Output - A stop input contact will stop the pump operation and close a stop output contact for alarm or remote notification. A red light visibly indicates a stopped condition.

Pre-Stop Input - Orange light that gives warning, but pump continues to operate.

In addition to the features found standard on the EW Series, pumps with the EW-Y control module feature:

Analog Input Control - Fixed or scalable 4-20mA input control.

Pulse Input Control - Pulse input with multiply and divide features (1-9999). 12VDC output power supply for Hall Effect water meters.

Flow Display and Totalization - After calibration the EW will totalize the volume feed and display the flow rate. As long as stroke length is constant the pump will accurately totalize all feed. In cases where the pump is being controlled external with a pulse the pump will display and count down remaining flow based on the pulse input. Coupled with the Posiflow feed verification the EW is equipped to ensure proper feed to your application.

Feed Verification - The EW is equipped with 3 pre-programmed modes for accepting our Posiflow Feed Verification Sensor. The Posiflow provides a pulse feedback to the pump to verify prime and proper feed. Depending on the mode, the user can program to pump to stop, continue operating and/or send an alarm based on the Posiflow input.

Quick-Prime - Hold 2 keys down and pump runs at 100% of speed to prime quickly without adjusting application settings.

Keypad Lock-Out - Keypad functions can be locked out providing feed security, programming integrity and protection from unwanted adjustments.

Easy Draw-Down Calibration - In the calibration mode the user only needs to start and stop the pump, enter the draw-down volume and the pump calibrates volume-per-stroke.



EW with Posiflow



EW with Multifunction Valve & Posiflow

2-Year Warranty
 "Bumper-to-Bumper" On All
 E-Class Pumps
 - Including Worned Parts

Electrical

EW

50/60 Hz, single phase
115 VAC ± 10%
230 VAC ± 10%

EWB

20 Watt avg.
0.8 Amp max.
0.4 Amp max.

EWC

22 Watt avg.
1.2 Amp max.
0.6 Amp max.

Shipping Weight (approximate) 12 lbs (5.5kg)

14 lbs (6.4kg)

Operating Conditions

Ambient temperature 32°F to 122°F (0°C to 50°C)
Relative humidity to 85%
Liquid temperature 32° to 104°F (0 to 40°C) for PVC based liquid ends
32° to 140°F (0 to 60°C) for PP, PVDF, SS based liquid ends
Below 32°F (0°C), pump is limited to 70% of max. pressure. Liquid cannot freeze.

Dimensions

Safety Performance

The EW Series metering pumps have been UL tested to meet UL and CSA standards.

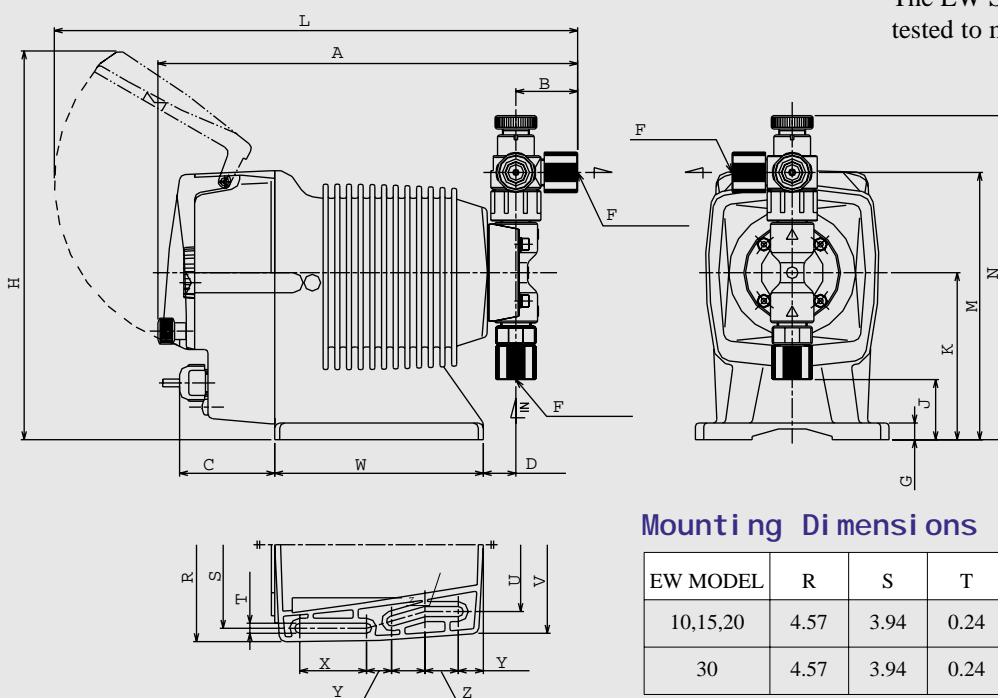

Mounting Dimensions (inches)

EW MODEL	R	S	T	U	V	X	Y	Z
10,15,20	4.57	3.94	0.24	3.15	4.17	1.57	0.59	0.79
30	4.57	3.94	0.24	3.15	4.17	1.57	0.59	0.79

EW MODEL	A	B	C	D	F	G	H	J	K	L	M	N	W
10,15,20	9.92 ¹	1.46 ¹	2.24	0.77	ø1/4 x ø3/8	0.39	9.17	1.42	3.94	12.36 ¹	6.30 ²	7.64 ³	4.92
30	10.12	1.50	2.24	0.93	ø3/8 x ø1/2	0.39	9.17	0.71	3.94	12.56	7.17	8.43	4.92

Notes for EW10, 15, 20:

1. Addition of a Multifunction valve increases overall length by 0.37". Addition of an Auto Air Vent Valve increases overall length by 1.59".
2. Addition of a Multifunction Valve increases discharge height by 0.22". No change for the Auto Air Vent Valve.
3. Addition of a Multifunction Valve increases overall liquid end height by 1.16". No change for the Auto Air Vent Valve.

Standard Materials of Construction

CE	Alumina ceramic	PTFE	Polytetrafluoroethylene
EPDM	Ethylene propylene diene monomer	PCTFE	Polychlorotrifluoroethylene
FKM	Fluoroelastomer	PVC	Polyvinylchloride (translucent)
GFRPP	Glass fiber reinforced polypropylene	PVDF	Polyvinylidene fluoride
PE	Polyethylene	M-PVC	Machined polyvinylchloride

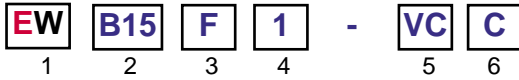

1 PUMP SERIES

EW IP65 electronic metering pump with external pulse control or manual speed control (adjustable to 360 strokes per minute) and manually adjustable stroke length. (Turndown ratio 1800:1)

2 CAPACITY/PRESSURE RATING

Size	Max. Output Capacity		Max. Output per Stroke	Max. Pressure ¹		Connection Size (in) Tubing O.D.
	GPH	ml/min	ml	PSI	MPa	
B10	0.6	38	0.11	150	1.0	3/8
B15	1.0	65	0.18	105	0.7	3/8
B20	1.8	115	0.32	60	0.4	3/8
B30	3.3	210	0.58	30	0.2	1/2
C15	1.3	80	0.22	150	1.0	3/8
C20	2.3	145	0.40	105	0.7	3/8
C30	4.3	270	0.75	50	0.35	1/2
C35 ²	6.7	420	1.17	30	0.2	1/2

¹ Auto Air vent valve reduces maximum pressure approx. 35 PSI (0.2 MPa)

² Output of the EWC35-TC/FC/SH is 6.3 GPH (400 ml/min)

3 CONTROL MODULE

F = For use on all EW models, features digitally adjustable speed and external pulse input control, stop & pre-stop inputs.

Y = For use on all EW models, features analog input, digital input w/multiply & divide, PosiFlow input and alarm outputs.

4 VOLTAGE

1 = 115VAC, 50/60 Hz

2 = 230VAC, 50/60 Hz

5 LIQUID END

Liquid End	Pump Head & Fittings	Diaphragm	Valve Balls	Valve Seat	Valve Seals	Gasket	Tubing
FC	PVDF	PTFE BONDED TO EPDM	CE	PCTFE	PTFE	PTFE	PE
PC	GFRPP		CE	FKM	FKM		
PE	GFRPP		CE	EPDM	EPDM		
VC	PVC		CE	FKM	FKM		
VE	PVC		CE	EPDM	EPDM		
VF	PVC		PTFE	EPDM	EPDM		
TC	PVDF		CE	FKM	FKM		
SH	316SS		HC	HC	PTFE	1/4" NPTF	

6 OPTIONS

C = High compression configuration: supplied standard with Auto Air Vent Valve in place of manual air vent valve. Available for B10, B15, C15 and C20 sizes with -VC liquid ends only.

M = Multifunction Valve is supplied in place of the manual air vent valve. Available for the 10, 15 and 20 size pumps with VC, VE, VF, PC, PE, PCH and PEH liquid ends. Not available with the AAVV feature.

CONNECTORS (ORDERED SEPARATELY)

E90494 4-Pin, Reverse Key Connector. Use for Stop/Pre-Stop inputs on EW/EW-Y.

E90495 5-Pin Connector. Use for Pulse in and Outputs on EW. Use for digital or analog inputs on EW-Y. Supplied standard with EW-Y pumps.

E90496 5-Pin, Reverse Key Connector. Use for Posiflow input on EW-Y.

E90497 4-Pin Square Connector. Use for output connectors on EW-Y.

All pumps include a manual air vent valve with the exception of FC liquid ends. All pumps include one foot valve, one injection valve, 20 feet of polyethylene tubing and one ceramic weight.



WEBMASTER GENERAL INDUSTRIAL CONTROLLER



WEBMASTER COOLING TOWER/BOILER CONTROLLER



METERING PUMP AND ACCESSORIES



WEBALERT REMOTE MONITORING & DATALOGGING

Walchem designs and manufactures an integrated line of analytical control, sensing and metering equipment.

Our in-house engineering is driven by quality, technology and innovation.

For more information on the entire Walchem product line, visit : www.walchem.com

WALCHEM

180247.C 2/26/04