

# PISTON PUMP INSTALLATION MANUAL

## GENERAL

The Piston Pump is a rugged positive displacement pump designed for reliable long life service. Like any other mechanical equipment, its performance and service life are affected by its conditions of use and maintenance. The pump should be located in an area away from excessive heat, freezing temperatures, or exposure to moisture and where it is accessible for routine inspection and lubrication. Installation should conform to local code requirements.

## INSTALLATION

In order to provide best performance and minimum maintenance, the following installation conditions are recommended.

- The pump should be mounted below its supply tank to facilitate a flooded suction to the pump. If the pump needs to be mounted above the supply tank, the use of a foot valve in the tank is recommended. In all installations, it is advisable to use as short a suction line as possible and sized large enough to accommodate sufficient flow to the pump suction. A strainer installed in the suction line to the pump will help prevent dirt or other contaminants from fouling the pump check valves. A graduated cylinder in the suction line will aid in pump calibration.
- **A pressure relief valve (PRV) is supplied with every pump and must be installed in the discharge line.** Install the PRV in a tee as close to the pump as possible and pipe the discharge of the PRV back to the supply tank or to the suction of the pump. Failure to install or properly adjust the PRV could endanger operators or equipment.
- The pump discharge connection to the process should be to a point above the level of the supply tank or at a pressure differential greater than the suction head from the supply tank to minimize the possibility of siphoning. If siphoning is a problem, then an anti-siphon valve installed in the discharge line may be necessary. Installation of an injection nozzle at the discharge point will aid in chemical dispersion and help prevent back feed from the process.
- Installing an additional tee and a valve in the discharge line near the pump will aid in bleeding air from the system should priming be necessary or to take a sample of the material being pumped. An addition tee and a pressure gauge is a nice addition for adjusting the PRV or indicating system pressure.
- Check the motor nameplate to be sure the motor electrical characteristics match the available power source.
- **A breather plug is supplied and must be installed on any flange mount or coupling drive speed reducer.**

## PRE-STARTUP

- Fill drive bearing area with grease.
- Check to be sure all piping connections are secure and do not leak.
- Open suction line supply valve.

## STARTUP

- Prime the pump. Priming the pump is best accomplished if there is no pressure on the discharge of the pump. If the pump will not self prime at startup, it may become necessary to open the bleed valve, if installed, or break a connection in the discharge line to allow air to bleed out. In extreme situations, if the pump discharge check valve is spring loaded and the piston size is 3/8" or 1/4", it may be necessary to remove the discharge check valve and fill the head with liquid. Reinstall the discharge check valve and the pump should then prime on its own. Once the pump is primed, close the bleed valve or any connection that was broken for the purpose of priming.
- The pressure relief valve (PRV) is a safety device factory set to the pressure setting marked on the attached tag. Check this value against the system pressure you need to overcome. The PRV needs to be set at a pressure greater than the system pressure but below the safe working pressure of all equipment the pressure will see. A pressure gauge in the discharge line would aid in setting the PRV. Adjustment of the PRV is done by removing the plastic cap and turning the set screw underneath clockwise to increase or counter clockwise to decrease the pop off pressure. Take care not to bottom out the set screw against the spring and ball beneath it. After adjustments are complete, reinstall the plastic cap.
- Adjust the volume output of the pump to meet your requirements. The volume output of the pump is varied by adjusting the stroke length of the piston. The knurled adjustment screw on the end of the slide assembly can be backed out to shorten the stroke and consequently lessen the volume output. Graduated lines on the slide assembly correspond to volumes on the output chart attached to the plastic cover over the pump casting. These settings for the various pump models are only approximate and may need tweaking depending on system parameters. A graduated cylinder plumbed into the pump suction line will allow for accurate stroke setting.
- **After a couple hours of pump run time, check the pump and associated piping for leaks. On pumps with packing nuts, it may be necessary to tighten them a quarter turn or so to insure the packing is snug.**

## **GENERAL MAINTENANCE**

- The slide and drive bearing should be greased monthly.
- Pump heads should be greased at least every 500 hours of normal operation. Over greasing is not possible so greasing more often than necessary is better than not enough or not at all.
- Packing nuts need to be snugged periodically depending on pump use and application. Material seeping between the piston and the packing is a good indication that the packing nut needs adjustment. Persistent seeping even after adjustment indicates the piston and packing may be worn to the point of needing replacement. Caution operators not to over tighten packing nuts as this will cause premature failure of the piston and packing and also put undue strain on the pump drive system. Pumps with 1" and larger pistons have spring loaded packing and packing tension adjustment is automatic.

## **TROUBLE SHOOTING**

### **UNDERFEED**

- Air bound-Bleed air from the discharge lines.
- Check valves not seating-Clean or replace the check valves.
- Ball checks floating-Spring load the ball checks or thin the material being pumped.
- Restricted suction-Clean the strainer and use a larger suction line.
- Pressure relief valve bypassing-Adjust the PRV for higher pressure, clean PRV seat or replace.

### **OVERFEED**

- Siphoning-Raise the discharge point above the level of the supply tank or install an anti-siphon valve.
- Too much suction head-Use a smaller day tank or install a pressure reducing valve in the suction line.

### **MOTOR FAILURE**

- Excessive discharge pressure for motor horsepower-Go to ½ HP motor vs ¼ HP
- Discharge line restricted or too small- Check for blockage or increase size of the discharge line.
- Insufficient ventilation-Ambient temperature needs to be below motor rating.
- Lack of lubrication-Check for mechanical strain due to lack of lubrication and correct.
- Low supply voltage-Check voltage to pump motor under load and increase wire size if necessary.
- Water or chemical spillage-Insure the motor is not being exposed to chemical dripping, spillage, or hosed water.

### **CHEMICAL LEAKING FROM PUMP**

- Packing nut loose-Adjust packing nut to tighten the packing and lubricate.
- Packing and/or piston worn-Check chemical compatibility and replace the piston and packing accordingly and lubricate.

## **REPLACEMENT PARTS**

When ordering replacement parts, it is helpful to have the serial number of the pump. The serial number is stamped into the lower right side of the pump base casting, under the plastic cover. This number will tell us everything we need to know about the original pump. If the serial number is not available a pump model number, stroking rate, piston diameter, head material, and motor nameplate data should be sought.

## **SPEED REDUCER LUBRICATION**

V-5 and V-10 pumps are shipped from the factory with the speed reducer filled with the proper amount of lubricant to operate within a 30 to 100 degree Fahrenheit ambient temperature range. The 60, 30, and 18 RPM output units are single reduction and the 12, 6, and 1 RPM output units are double reduction. Double reduction units have separate oil sumps and must be filled/checked independently. Prior to startup, verify that the oil level is at the proper level, by removing the level inspection plug which is positioned about the center of the output shaft on the side of the unit opposite the input shaft. The oil level should be at or near this level. If the ambient temperature will be outside the range for the lubricant installed at the factory, drain and refill the reducer with the proper viscosity lubricant prior to use. Consult the factory or the chart below for alternate lubricants. Be sure to install the breather plug in the proper location on the side of the reducer, near the top of the reducer.

**Change Intervals: Standard compounded lubricants should be changed every six months or 2500 operating hours, whichever comes first. Factory installed synthetic lubricants should be changed every two years or 6000 hours, whichever comes first. Oil should be changed more often if reducer is used in a severe environment. The factory supplied oil is not suitable for the Food and Drug Industry.**

<b>MANUFACTURER</b>	<b>30-100 DEGREE F AMBIENT</b>	<b>50-125 DEGREE F AMBIENT</b>
	<b>AGMA Compounded #7</b>	<b>AGMA Compounded #8</b>
<b>Amoco Oil Co.</b>	<b>Worm Gear Oil</b>	<b>Cylinder Oil #680</b>
<b>Chevron USA, Inc.</b>	<b>Cylinder Oil #460X</b>	<b>Cylinder Oil #680X</b>
<b>Exxon Co. USA</b>	<b>Cylesstic TK-460</b>	<b>Cylesstic TK-680</b>
<b>Gulf Oil Co.</b>	<b>Senate 460</b>	<b>Senate 680D</b>
<b>Mobile Oil Corp.</b>	<b>600 W Super Cylinder</b>	<b>Extra Hecla Super</b>
<b>Shell Oil Co.</b>	<b>Valvata Oil J460</b>	<b>Valvata Oil J680</b>
<b>Sun Oil Co.</b>	<b>Gear Oil 7C</b>	<b>Gear Oil 8C</b>
<b>Texaco</b>	<b>Honor Cylinder Oil</b>	<b>650T Cylinder Oil</b>
<b>Union Oil Co. of CA</b>	<b>Steaval A</b>	<b>Worm Gear Lube 140</b>

# TYPICAL INSTALLATION OF THE PRESSURE RELIEF VALVE

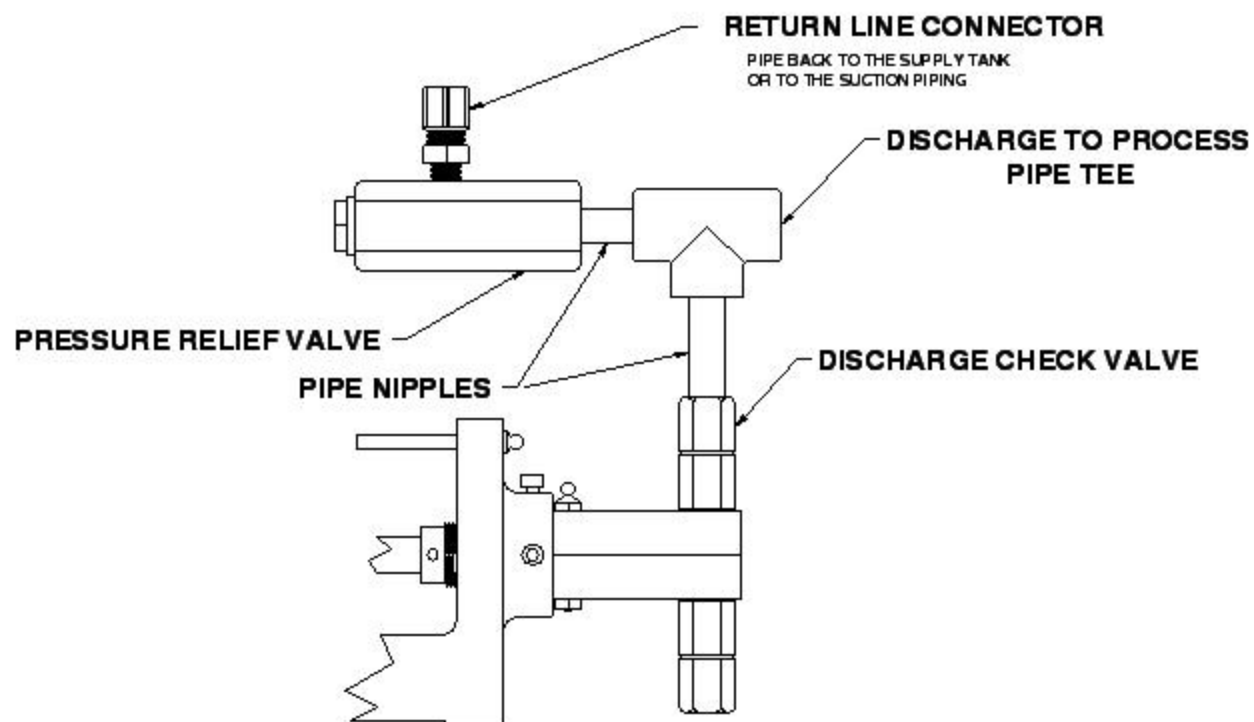

EACH PUMP IS SUPPLIED WITH A PRESSURE RELIEF VALVE FOR EACH HEAD ON THE PUMP. THE PRESSURE RELIEF VALVE IS A SAFETY DEVICE AND MUST BE INSTALLED IN THE DISCHARGE LINE OFF THE PUMP AS CLOSE TO THE DISCHARGE CHECK VALVE AS POSSIBLE. SET THE PRESSURE RELIEF VALVE AT A VALUE TO INSURE PROTECTION TO THE OPERATOR AND THE EQUIPMENT IN CASE OF A BLOCKAGE DOWN STREAM OF THE PUMP. FAILURE TO INSTALL OR PROPERLY ADJUST THE PRESSURE RELIEF VALVE COULD RESULT IN DAMAGE TO THE EQUIPMENT OR INJURY TO THE OPERATOR.

## #18 PRV

NOTE: TO FIELD ADJUST THE POP OFF PRESSURE, REMOVE THE CAP AND TURN SET SCREW CLOCKWISE TO INCREASE AND COUNTER CLOCKWISE TO DECREASE THE SET POINT.

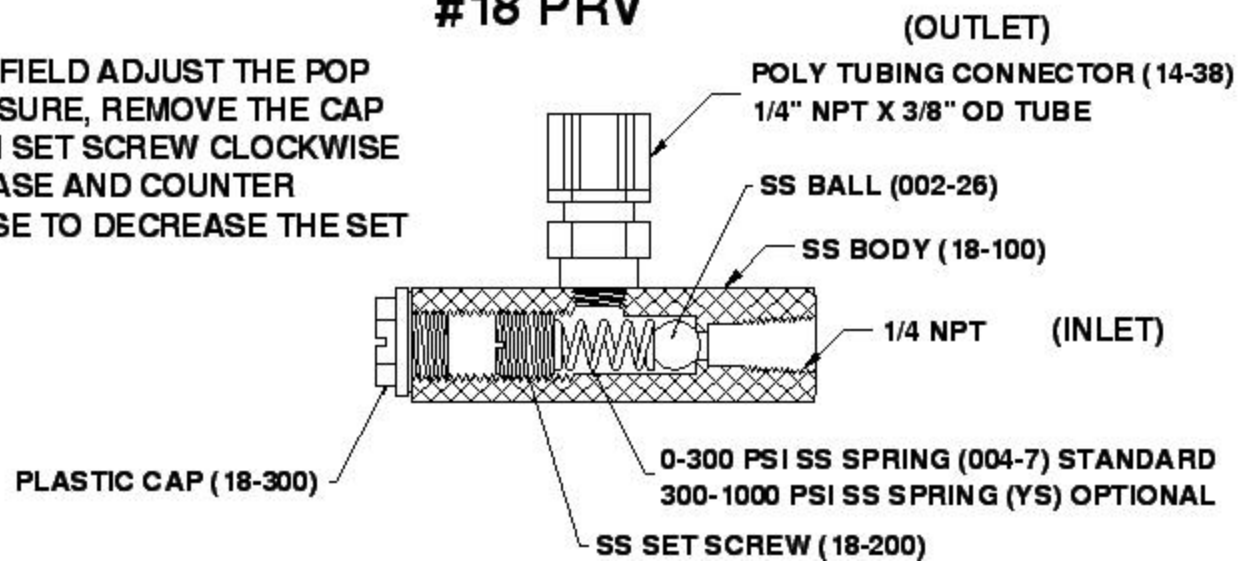

### RECOMMENDED INSTALLATION OF THE TREATMENT PUMP

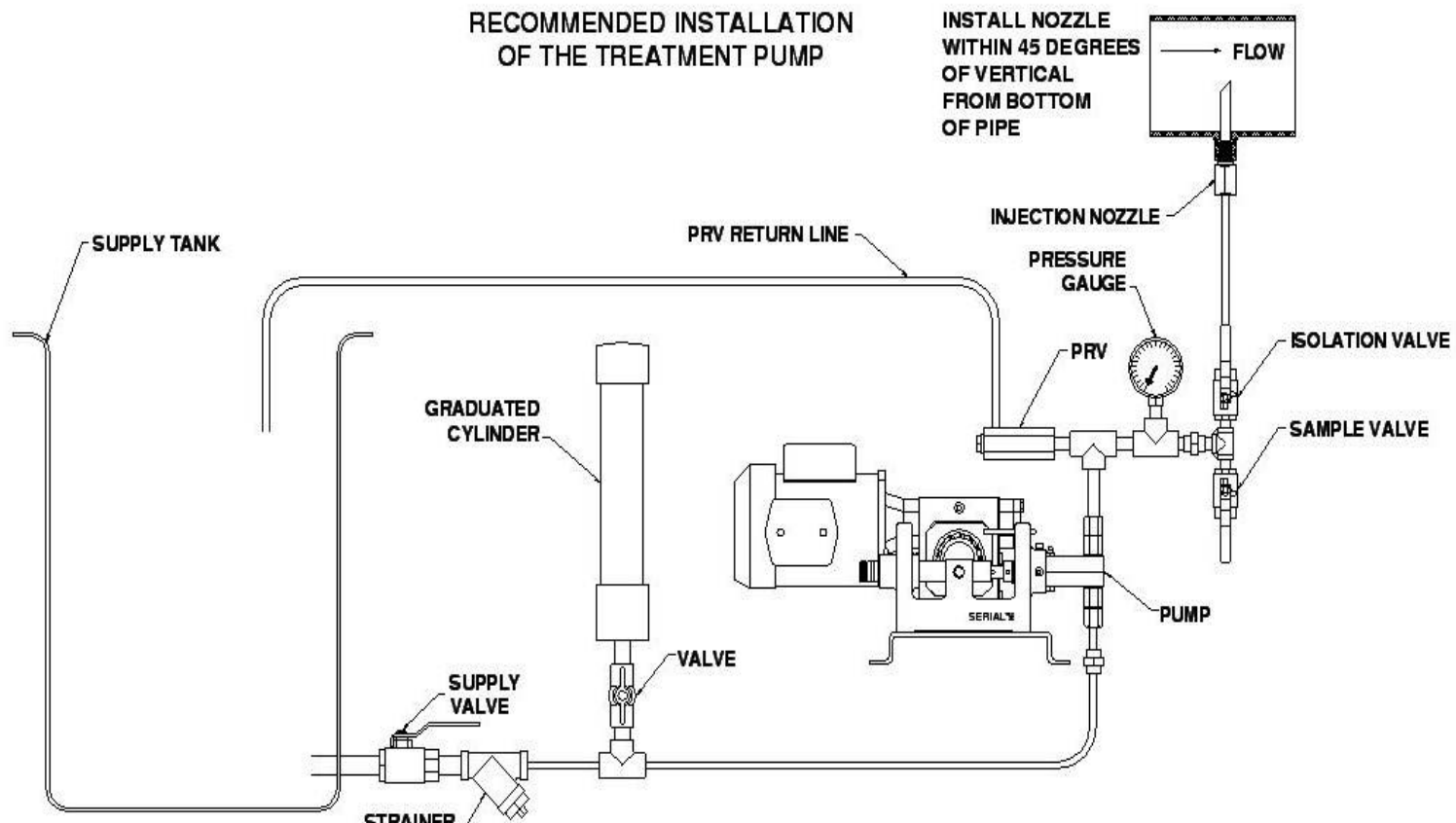

### RECORD PUMP INFORMATION

MODEL NUMBER

SERIAL NUMBER

DATE INSTALLED

NOTES

---

---

---

---

---

---

---

---